

MICRO MAX World Final Qualifier 2021

1.0 Group **Cadet**

1.1 Class **Rotax Micro Max**

Affiliation Commercial JAG Engineering

1.2 Chassis. **CIK homologated 950 chassis or UK/MSA homologated 900 Cadet chassis.** The chassis must remain as homologated in all respects and may only be subject to Karting UK approved modifications for safety reasons.

1.3 Engine. The only engine permitted is the Rotax FR125 MICRO MAX sealed and supplied by JAG/ROTAX. The engine is a single cylinder, liquid cooled, reed valve two stroke. All engines are sealed between cylinder, crankcases, cylinder head and the reed valve block with an official JAG/ROTAX seal.

All seals must be crimped with the official Rotax crimping tool part No.276 110. Each end of the sealing wire must only pass through the seal once

1.3.1 All engines and engine ancillaries must remain as supplied by JAG/ROTAX unless otherwise stated.

1.3.2 Modifications. Neither the engine nor any of its ancillaries may be modified in any way. "Modified" is defined as any change in form, content or function that represents a condition of difference from that originally designed. This is to include the addition and/or omission of parts and/or material from the engine package assembly unless specifically allowed within these regulations. The adjustment of elements specifically designed for that purpose shall not be classified as modifications.

1.3.3 Ignition System. Digital battery ignition system, variable ignition timing, no adjustments possible.

EVO Dell'orto ignition system: Ignition coil with separate ECU. The minimum length of HT lead permitted is 210mm from outlet of cable at ignition coil to outlet of cable at spark plug connector (= the visible length of wire). Spark plug cap must be red rubber version marked "NGK" or **ROTAX**. Senior ECU (Part No. 666815), mounting brackets, wiring loom, battery clamp (battery box) and all its components as described in the Rotax FR125 Max Fiche. Battery clamp (battery box) must be mounted on the left side of the chassis. Additional battery box mounting brackets may be used as supplied by JAG. Only YUASA YT7BBS Battery with Rotax branding supplied by JAG/Rotax for this event can be used.

1.3.4 Spark plug. NGK GR8DI

Electrode gap (maximum) Filler gauge 1.20 mm must not fit in between the two electrodes.

1.3.5 Intake Silencer. Only Type 2 may be used. The Intake Silencer/Airbox must be used unmodified as supplied by Rotax for the FR125 with its filter and all component parts including support bracket in place. The two halves of the airbox must be securely screwed together using 4 M6 screws. All 4 screws must be sufficiently tightened to securely clamp the two halves of the airbox together. Intake silencer tube and airbox-to-carburettor socket must be marked with "ROTAX" In all conditions the air box **MUST** be positioned with inlet trumpets to the bottom of the box. The air box must be securely fitted in a manner to prevent rotation. During wet condition, it is not allowed to attach anything to the air box to protect the air inlet from water spray.

1.3.6 Carburettor. Dell'orto VHSB 34 XS

All Carburettors will be supplied and sealed by JAG/Rotax.

XS carburettor: Needle jet DP267. Choke jet 60. Idle jet 60, idle jet emulsion tube 45. Needle K57. Float needle valve 150. Slide 45. Floats 4.0gr. The venturi insert must have 12.5 stamped on the top. Dellorto carburettor, housing must show the cast wording "VHSB 34" Carburettor housing is stamped with "XS". The complete inlet bore of the carburettor must show cast surface.

The two vent fittings must be connected with the original air vent hose min 155 mm (Rotax 260260). The location of the opening has to be placed at the rear side of the carburettor. Settings of the carburettor adjustment screws (idle and idle air) are free. The position of the jet needle is free. All jets must be correctly seated and securely fitted at any time (tightened). The complete inlet bore of the carburettor housing must show cast surface. The venturi hole of the carburettor insert can show signs of a CNC control machining. Only main jet sizes listed in the supplementary regulations can be used

125 Micro MAX Throttle restrictor :

The throttle body restrictor (Rotax Part No. 267536) must be installed in the rear of the of the carburettor and in the correct orientation at all times (see picture 1 below for reference).the 125 Micro MAX class a throttle body restrictor / carburettor insert must be in place at all time as supplied by JAG/ROTAX.

Picture 1

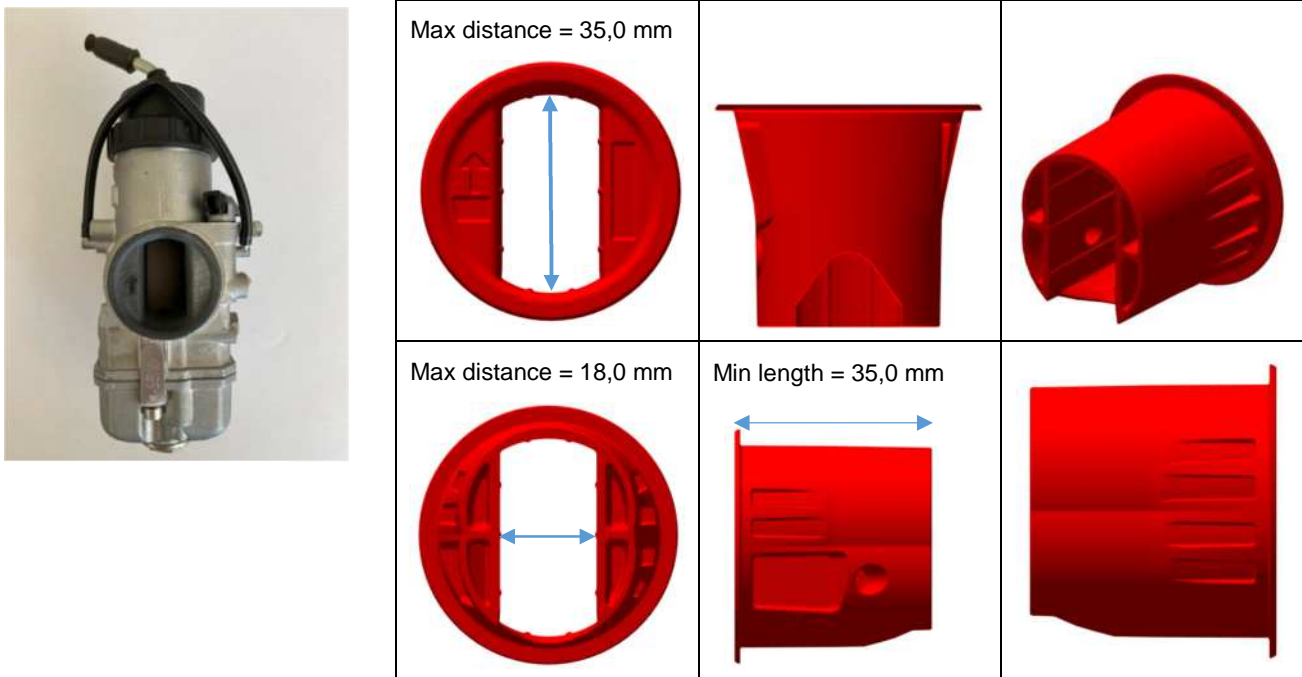

1.3.7 Fuel Pump. Only Mikuni – Fuel Pump DF 44-210 may be used. The fuel pump must be fitted to the bottom of the standard air box bracket. Only a single length of pulse tube from crankcase connector to fuel pump may be used. Only a single length of fuel line may be fitted between fuel pump and carburetor. Rotax in line fuel filter (part No. 2741612) must be used and fitted between fuel tank and fuel pump. Any type of fuel line can be used. No restrictors, fuel returns or additional reservoirs are permitted.

1.3.8 Radiator.

Radiator must be mounted with all components as shown in the respective illustration. To apply tape (neutral tape without advertising only) around the radiator is an allowed modification to control the air flow through the radiator. Tape may not be removed from the radiator during operation on the track. Any other non-original device to control the air flow through the radiator is prohibited. To remove the original flap is an allowed modification.

Only version 2 radiator can be used (see illustration)

Cooling area:

Height: 280 – 300 mm

Width: 58 – 62 mm

Thickness of radiator: 30 – 34 mm

To remove the original flap is an allowed modification.

Version 2 Radiator

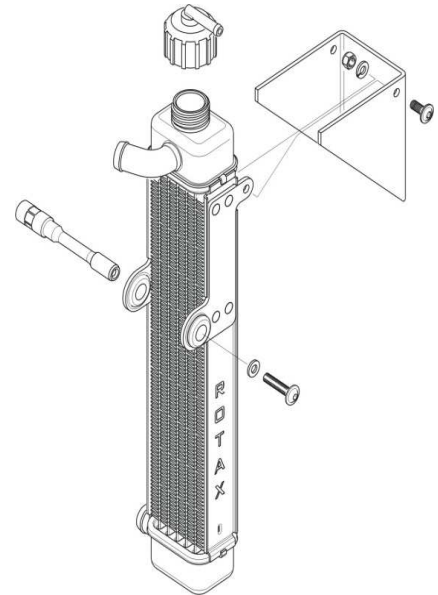

1.3.9 Engine coolant Plain water without any additives must be used.

1.3.10 Exhaust socket (Restrictor)

Exhaust socket with one gasket and sealing ring must be used

Diameter (A) must apply for a length (B) of at least 12 mm.

Maximum inner diameter (A) of exhaust sockets is:

125 Micro MAX: 18,20 mm (Rotax part no. 273 192)

The internal profile of the exhaust socket has to be checked with the template, Rotax 277 405.

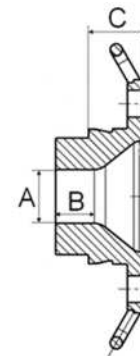

Fit the template (**125 Micro MAX “18 mm”**) as far as possible into the exhaust socket (without gasket, carbon deposits removed). There has to be a constant crack light between the profile of the exhaust socket and the profile of the template.

All exhaust gases must pass through the Exhaust socket restrictor

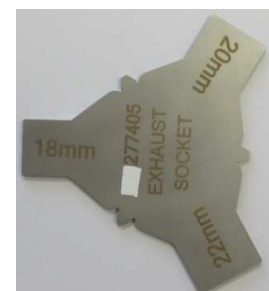

1.3.11 Squish gap: Minimum 2.4 mm

Average of two measurements. To be measured on both sides across piston pin axis using ROTAX 3mm tin (Rotax 580132)

1.4 Exhaust System. Exhaust system (Part No. 273136) will be supplied sealed by JAG/ROTAX. A specific exhaust system has to be used for the 125 Micro MAX engine. The exhaust must be used as supplied by JAG/ROTAX with the seal in place at all times. The Exhaust must be installed firmly to the chassis using a rigid pipe mount/s. The exhaust pipe must be mounted to the rigid pipe mount using 2 ROTAX silent blocks. (part 660920 and or 260657 allowed). The deflection of the 2 silent blocks is the only pipe movement allowed. The pipe must be mounted in a neutral position with no stress on the 2 silent blocks. The use of maximum 4 pieces of original Rotax exhaust springs, to fix the exhaust system to the cylinder is allowed. (a “safety wire” in the exhaust flange area is not allowed). The silencer must be mounted in a position where the direction of the 90° elbow outlet (direction of the hot exhaust gasses) does not harm any component of the chassis.

The measurements in the diagram below are as follows:

- (a) 580 mm +/- 5mm
- (b) 299 mm +/- 5mm
- (c) 42 mm +/- 3mm

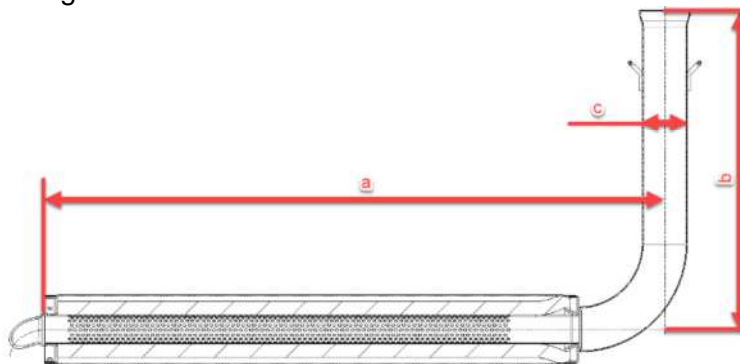

1.5 Transmission. Clutch components must be as supplied by Rotax.

The internal running surface of the clutch must remain dry and free of grease or lubricant or any additional substance. The engine clutch must be triggered at 4000 rpm maximum and make the kart and Driver move forward.

All sprockets must use a 15 x 19 x 17 needle cage bearing and O-ring seal. An 11 tooth sprocket must be fitted with a plain bearing and O-ring seal.

Thickness of clutch shoe (A):
Minimum = 24.10 mm

Measurement must be done at the 3 open ends of the clutch, 5 - 10 mm from the machined groove (all clutch shoes must be completely closed at measurement – no gap).

Height of clutch (B):
Minimum = 11.45



Clutch drum outer diameter (C)

Minimum = 89,50 mm

Clutch drum Inner diameter (D)

Maximum = 84,90 mm

Clutch drum Height (E) with sprocket/primary gear

Minimum = 33,90 mm

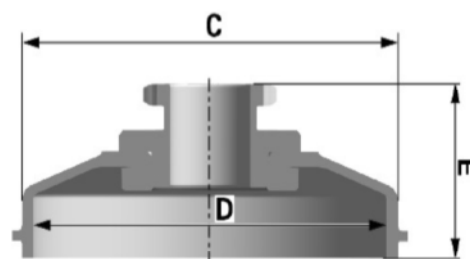

1.5.1 Gear ratio. Only nominated gear ratios can be used. Nominated gear ratios will be specified in the supplementary regulation

1.6 Fuel/Oil. Motorsport UK Championship fuel. XPS KART TEC DYE, 2-stroke oil.

1.7 Tyres.

Dry – ‘Dunlop LS2-MSA’ Front 10 x 3.6 x 5, Rear 11 x 5 x 5. Barcoded

Wet – ‘Dunlop KT3’ Front 10 x 3.6 x 5, Rear 11 x 4.5 x 5. Barcoded.

1.8 Weight. Minimum 108kg, including the driver. Minimum driver weight as per U17.29.6 is 29kg

1.9 Number Plates. Yellow with black numbers.

1.10 Age. 8th birthday to 31st December of the year of 11th birthday.

1.11 Data Logging. Data logging is permitted; data logging systems with or without memory may be used. Global navigation satellite system reception is permitted. It is only permitted to take readings of engine rpm, engine water temperature, speed of 1 wheel, an X/Y accelerometer, lap times and split lap times. The engine water temperature sensor may only be fitted in the position provided in the cylinder head cover for this attachment. The rpm, may only be recorded via a sensor on the HT lead to sense spark plug pulses. The HT lead must remain a single length from ignition coil to spark plug cap. The fitting of these sensors is only permitted providing there is no modification to the original engine components.